

Lecture 1: Common Emitter Amplifier.

We will now begin the analysis of the **three basic types** of linear BJT small-signal amplifiers:

1. Common emitter (CE)
2. Common base (CB)
3. Common collector (CC), which is oftentimes called the emitter follower amplifier.

We'll study the CE amplifier in this lecture and the next, followed by the CB and CC amplifiers.

The CE amplifier is excited at the base of the BJT with the output taken at the collector:

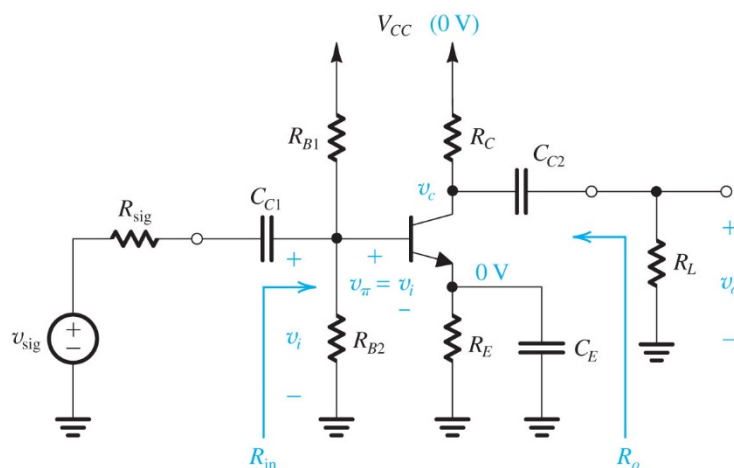

(a)

(Fig. 7.56a)

The capacitor C_E is called a **bypass capacitor**. At the operating frequency, its purpose is to **shunt out** the effects of R_E from the time varying signal. In other words, C_E sets an AC ground at this node at the frequency of operation.

There are a **number of ways to bias this amplifier**, other than that shown above. What we're primarily interested in here is the small-signal characteristics.

Common Emitter Small-Signal Amplifier Analysis

The small-signal equivalent circuit for the CE amplifier above is shown below. Because the emitter is located at an AC ground is the reason this type of amplifier is called a “**common emitter**” amplifier.

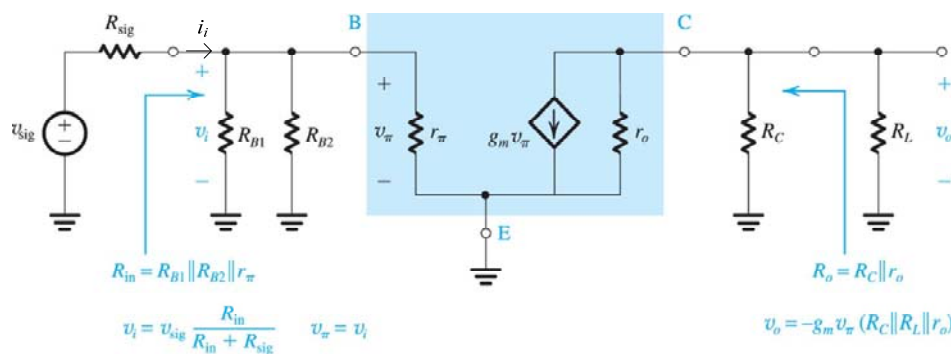

(b)

(Fig. 7.56b)

Notice that we've included r_o in this small-signal model. This is the finite **output resistance** of the BJT. This accounts for the finite slope of the characteristic curves of i_C versus V_{CE} :

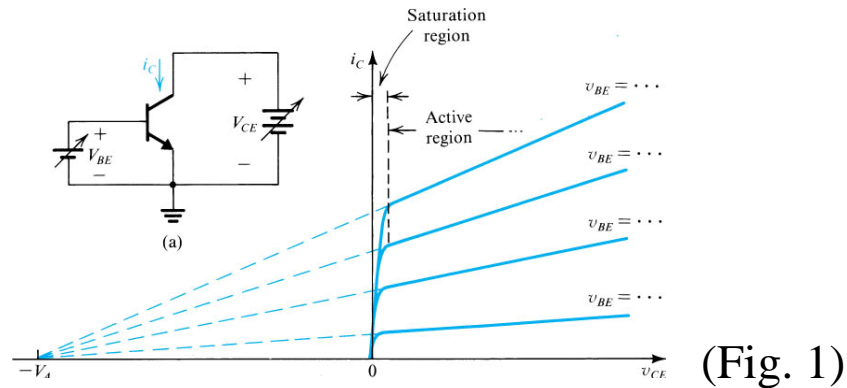
(Fig. 1)
(Sedra and Smith, 5th ed.)

where V_A is called the **Early voltage**. Usually r_o is fairly large, on the order of many tens of $k\Omega$.

Our quest in the small-signal analysis of this amplifier is to **determine these quantities**: input resistance R_{in} , the “overall” small-signal voltage gain $G_v = v_o/v_{sig}$, the “partial” small-signal voltage gain $A_v = v_o/v_i$, the overall small-signal current gain $G_i = i_o/i_i$, the short circuit small-signal current gain $A_{is} = i_{os}/i_i$, and the output resistance R_o .

- Input resistance, R_{in} . Directly from the small-signal equivalent circuit, we see that

$$R_{in} = R_{B1} \parallel R_{B2} \parallel r_{\pi} \quad (7.151),(1)$$

Oftentimes we select $R_{B1} \parallel R_{B2} \gg r_{\pi}$ so that

$$R_{in} \approx r_{\pi}$$

r_{π} will often be a few $k\Omega$, which means this CE amplifier presents a moderately large value of input impedance.

- Overall small-signal voltage gain, G_v . By “overall” voltage gain we mean

$$G_v \equiv \frac{v_o}{v_{\text{sig}}} \quad (2)$$

which is the **actual small-signal voltage gain** that would be realized in the circuit above. At the output of this circuit

$$v_o = -g_m v_\pi (r_o \parallel R_C \parallel R_L) \quad (3)$$

while at the input

$$v_i = v_\pi = \frac{R_{\text{in}}}{R_{\text{in}} + R_{\text{sig}}} v_{\text{sig}} \quad (4)$$

Substituting (4) into (3) and using (1) gives an expression for the overall (i.e., realized) gain of this CE amplifier

$$G_v = \frac{v_o}{v_{\text{sig}}} = \frac{-g_m R_{\text{in}}}{R_{\text{in}} + R_{\text{sig}}} (r_o \parallel R_C \parallel R_L) \quad (7.152), (5)$$

In the not uncommon case that $R_{B1} \parallel R_{B2} \gg r_\pi$, then $R_{\text{in}} \approx r_\pi$ and (5) becomes

$$G_v \approx \frac{-\beta (r_o \parallel R_C \parallel R_L)}{r_\pi + R_{\text{sig}}} \quad (6)$$

Recall that $r_\pi = \beta / g_m$. If it also turned out $R_{\text{sig}} \gg r_\pi$, then we see from (6) that G_v would be **directly dependent on β** . This is **not a favorable condition** since, as we learned when discussing biasing of such BJT circuits, β can vary considerably between transistors.

- Partial small-signal voltage gain, A_v . This is only a partial voltage gain since we are calculating

$$A_v \equiv \frac{v_o}{v_i} \quad (7)$$

At the input, $v_i = v_\pi$ while at the output,

$$v_o = -g_m v_\pi (r_o \parallel R_C \parallel R_L) \quad (8)$$

Therefore, the partial small-signal voltage gain is

$$A_v = -g_m (r_o \parallel R_C \parallel R_L) \quad (9)$$

- Overall small-signal current gain, G_i . By definition

$$G_i \equiv \frac{i_o}{i_i} \quad (10)$$

Referring to the small-signal equivalent circuit shown above, we see that

$$i_i = \frac{v_i}{R_{in}} \quad \text{and} \quad i_o = \frac{v_o}{R_L}$$

Forming the ratio of these two currents, we find that the current gain is

$$G_i = \frac{i_o}{i_i} = \frac{R_{in}}{R_L} \frac{v_o}{v_i} \stackrel{(7)}{=} \frac{R_{in}}{R_L} A_v \stackrel{(1)}{=} \frac{r_\pi \parallel R_{B1} \parallel R_{B2}}{R_L} A_v$$

and, using (9)

$$G_i = \frac{-g_m (r_\pi \parallel R_{B1} \parallel R_{B2})(r_o \parallel R_C \parallel R_L)}{R_L} \quad (11)$$

- Short circuit small-signal current gain, A_{is} . This is the small-signal current gain of the amplifier but with a **short circuited load** ($R_L = 0$):

$$A_{is} \equiv \frac{i_{os}}{i_i} \quad (12)$$

Equivalently,

$$A_{is} = G_i \Big|_{R_L=0} \quad (13)$$

Using (11) in (13) with $R_L \rightarrow 0$ gives

$$A_{is} = -g_m (r_\pi \parallel R_{B1} \parallel R_{B2}) \quad (14)$$

In the not unusual case that $R_{B1} \parallel R_{B2} \gg r_\pi$ then

$$A_{is} \approx -\beta \quad (15)$$

This result is **not unexpected** because β is by definition the short circuit current gain for the BJT when operating in the active mode.

- Output resistance R_o . Using the small-signal equivalent circuit above, we **short out** the source ($v_{sig} = 0$) which necessarily means that $v_\pi = 0$ as well. Therefore, $g_m v_\pi = 0$, which is an open circuit for a current source.

Consequently,

$$R_o = R_C \parallel r_o \quad (16)$$

which is generally fairly large.

Summary of CE Amplifier Characteristics

Summary for the common emitter amplifier:

- ✓ Big voltage and current gains are possible.
- ✓ Input resistance is moderately large.
- ✓ Output resistance is fairly large.

This last characteristic is often **not desirable**. Why? Consider this simple Thévenin equivalent for the output of a small-signal amplifier:

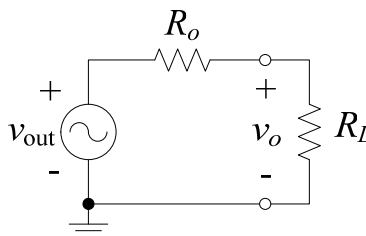

The output signal voltage provided to this resistive load is

$$v_o = \frac{R_L}{R_L + R_o} v_{\text{out}} \quad (17)$$

Now, if $R_o \gg R_L$ then

$$v_o \approx \frac{R_L}{R_o} v_{\text{out}} \quad (18)$$

This is not a favorable result if this Thévenin equivalent circuit represents an **amplifier** because the output voltage is being **attenuated**. Conversely, **if** there were a *small* output resistance such that $R_o \ll R_L$ then (17) becomes

$$v_o \approx v_{\text{out}} \quad (19)$$

which is much more favorable for an amplifier.